



DVTP Double Stages High Vacuum Transformer Oil Purification System

Acore Filtration Co.,Ltd provides engineering, manufacturing, sales of industrial oil filtration systems, we have been striving for studying the user's requirement and provide filtration solutions for every demanding application on global scale.

Acore's filtration systems can help customers improve the quality of oil, extend equipment life, reduce maintenance costs and keep equipment working at peak efficiency. Meanwhile, they are very effective, durable and user-friendly systems.



Introduction:

Power transformers are complex and responsible elements in systems for production and distribution of electric energy. Good functioning, work security and working life of transformers mainly depend on the state of their isolation system, which provides mechanical strength, dielectric strength and dielectric distance, while insulating oil has the function of providing cooling, dielectric strength and proper isolation protection, so the isolation system is highly sensitive to deterioration of the insulating oil.

By analyzing, moisture contamination is one of the most obvious causes of deterioration in the insulating quality of transformer oil, the amount of moisture that can be dissolved in oil increases rapidly as the oil temperature increases and stir up the gas bubbles. Meanwhile, inside transformers, the particles, sludge sticks to the surfaces of transformers through heat should be dissipated, they forms a blanket barrier to the flow of heat from the oil to the coolant and from the core and coils to the cooled oil. Otherwise, faults involving overheating of cellulose insulation generate mainly carbon monoxide and carbon dioxide. At the relatively low temperature and energy dissipation of partial discharges, the only gas produced is H₂. Low temperature and localized overheating produces CH₄ (methane) and C₂H₆ (ethane) and some hydrogen.

In order to lower the amount of moisture, gasses dissolved as much as possible, and also in order to eliminate solid products of oil oxidation process, the highly accepted concept of power transformers maintenance assume that activities of periodical purification of insulating oil are performed in the electric energy. For this purpose, ACORE Filtration Co. Ltd developed the DVTP Double Stage High Vacuum Transformer Oil Purification System (Oil Purifier Machine) to reduce moisture, gasses content and remove particles, sludge for improving dielectric strength and maintain the characteristics of insulating oil. Through timely and proper purification of insulating oil, which can improve the properties of the entire isolation system, maintain the normal functioning, good work security and extend the lifecycle of power transformers.



Applications:

DVTP Double Stages High Vacuum Transformer Oil Purification System(Oil Purifier Machine) is designed for purification of insulating liquids in the oil-filled electrical equipment, it can be used to degas, dehydrate, filtering and restores dielectric strength of insulating oils, Through the dehydrator, degasification, filtration processes, the dissolved gases and moisture, solid particulate, contamination can be completely removed. The purification range includes all insulating oils filled in transformers, circuit breakers, capacitor, cable, mutual inductor, above 110KV EHV transmission and distribution equipment, and more than 500KV UHV transformer insulating oil etc.

DVTP High Vacuum Transformer Oil Purifier allows the purification processing in workshop, in storage tanks, drums or directly online purification in transformers at site. It can be mounted on trailer and carried out off-load or on-load for customers' preference. It also allows efficient drying of the insulating coil and paper while maintaining the transformer and also can be for transformers oil-filling.

DVTP High Vacuum Transformer Oil Purifier are very effective, durable, and user-friendly high vacuum purification system on the market today. Special engineered design features maximize the water extraction rates of our systems, and top-quality components and workmanship ensure years of maintenance-free operation and performance.

Features

- Upgrading of new and used electrical insulating liquids, transformer oils.
- Double stages vacuum pumps, horizontal double vacuum dehydration, degasification chambers and blower capable of pulling vacuum down to 0.05 mbar.
- Micron filter elements with capable of removing 99.5% particles $\leq 1 \mu\text{m}$.
- Achieving overall water content of ≤ 3 PPM By vacuum dehydration to remove free, emulsified and dissolved water.
- Achieving soluble air and gas content of $\leq 0.05\%$ and dielectric strength of $\geq 75\text{kV}$ per ASTM 877.
- Low watt-density less than $1.5\text{W}/\text{cm}^2$ circulation heater with digital temperature controller.
- Different pressure gauge of filters, pressure protector, vacuum gauge and digital temperature gauge
- Online oil purification processing, vacuum drying and vacuum oil-filling for electric equipment.



Technical Specifications

Model	DVTP-50	DVTP-65	DVTP-80	DVTP-100	DVTP-150	DVTP-200	DVTP-250	DVTP-300	
Capacity(L/hour)	3000	4000	4800	6000	9000	12000	15000	18000	
Vacuum pressure	-0.08~-0.099 Mpa								
Working pressure	≤ 0.4 Mpa								
Temperature range	20-80℃								
Continuous work	≥200 hr								
No failure running	≥5000 hr								
Power supply	380V, 50HZ, 3PH (or Customized)								
Working noise	65 dB								
Heating power (kw)	30	40	48	60	90	125	136	150	
Total power (kw)	34	45	54	68	100	135	148	165	
Inlet/outlet(mm)	32	40	44	44	50	55	60	65	
Weight (kg)	600	700	800	900	1200	1800	1950	2300	
Dimension (mm)	L	1500	1600	1700	1800	2000	2100	2150	2300
	W	1450	1500	1550	1650	1750	1850	1950	2000
	H	1500	1650	1800	2000	2150	2200	2250	2300

Specifications after purification process

Item	Specifications
Breakdown voltage	≥ 70KV
Water content	≤ 3ppm
Gas content	≤ 0.05%
Filtering rate	≤ 1 micron (ISO 14/12/10)
Flash point (close cup)	≥135℃
Interfacial tension performance	> 40 Dynes / cm @ 25 C
Power factor performance	< 0.005 % @ 25 C

Flow Drawing

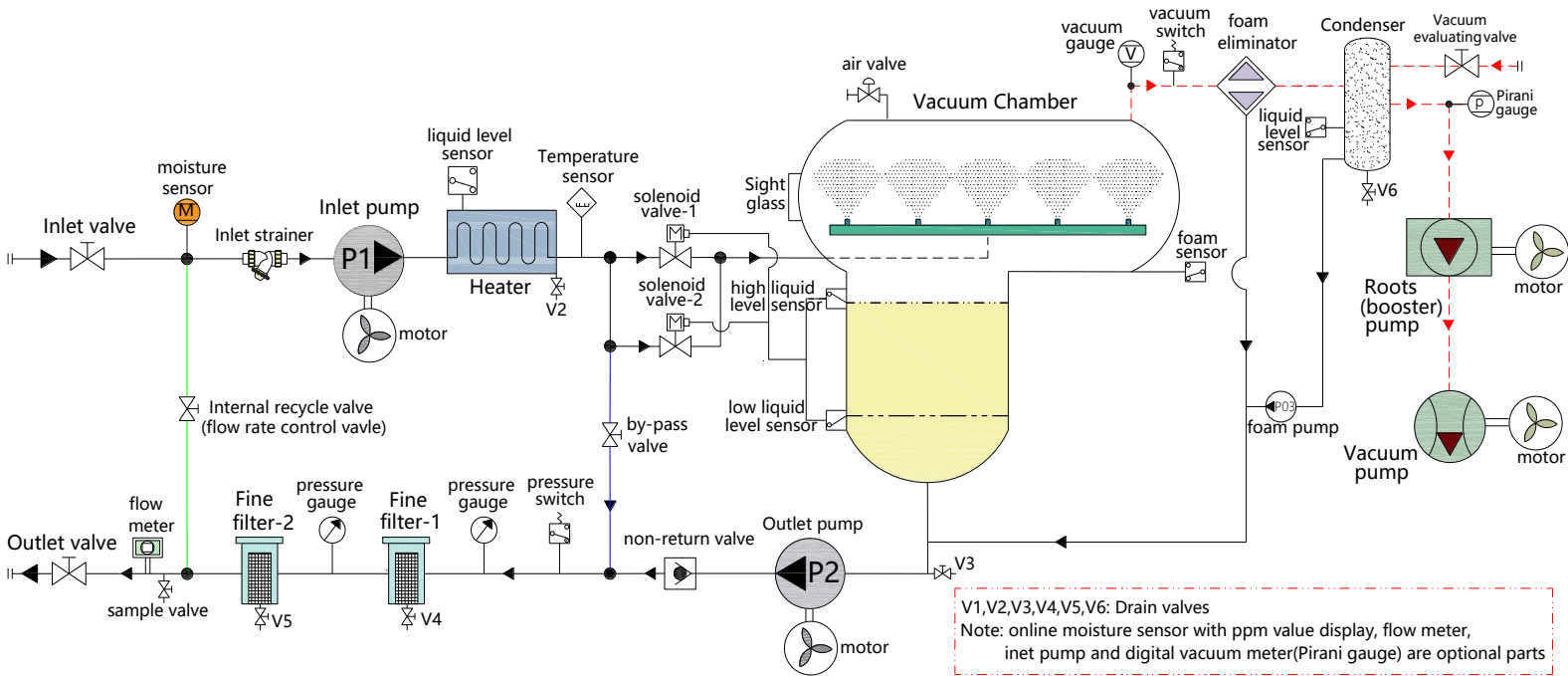

Specification Introduction of Components

1. Electric Control Panel

The plant is controlled by a complete automatic PLC system with touch screen, which allows easy and safe operation, it also allows operation over buttons on the control panel by manual. The controlling system of the plant has interlocked protective system and pressure protective device which will avoid overload, over voltage, pumping without oil, heating without oil, oil leak, electricity leak and prevent any damages to equipment due to operating error or power failure. The control panel also has alarm system for any fault, the alarm lamp will light and fault message will display on screen. Meanwhile, Timing counters for each running time and total running time.

2. Vacuum Dehydration & Degasification Chambers

Vacuum chambers are composed of double stages horizontal & vertical vacuum chambers(for 3000-6000L/H), and double stages horizontal vacuum chambers(>6000L/H). Under the high vacuum status, vacuum evaporation chambers enlarge evaporation area efficiently, leading to the formation of film-alike oil and stereo-evaporation.

A row of oil mist sprayers with rasching rings are provided in the vacuum chamber and become an evaporator, which spray oil film from down to top and greatly improves the surface area of oil exposed in vacuum system and extends sufficient time to ensure maximum working efficiency in the removal of gas and moisture.

A foam eliminator connected with foam sensor and foam pump to reduce oil foam in vacuum chamber and prevent oil getting into the vacuum pumps and damaging vacuum pump.

A vacuum gauge is provided to measures vacuum pressure in vacuum chamber and sight glass are provided for observation of oil flow

3. Liquid-level Controlling System

The latest magnetic liquid level controlling system is provided to prevent the oil level in the chamber from getting too high and too low. It connects with inlet/outlet pump, electromagnetic valve to control balance of inlet and outlet oil quantity, also prevents oil penetrating into vacuum pump and avoid outlet pump running without oil.

An automatic oil foam eliminator connects with foam sensor and foam pump to reduce oil foam and high oil level.

Automatic solenoid valves and non-return valve are provided to avoid mixing of processed and unprocessed oil, and prevent oil entering degassing chamber in case of power failure.

4. Heating System

The plant equips electric heater with digital temperature gauge, which connects a reliable thermocouple sensor as a safety thermostat mounted in heating vessel, it can check the oil level in heater and avoid heating without oil, at same time, the deterioration of oil caused by overheating is avoided. The temperature can be set by manually and with capable of heating oil from 20°C to 80°C. The designed temperature range can ensure the safety of plant and worker.

The heating components can warm up temperature around and heat radiation container can uniformly warm up the oil, adopting low load of heated surface with 1.5W/cm². The replacement of heating components is easy.

5. Feed Pump & Discharge Pump (Note: Feed Pump is optional)

Feed Pump(inlet pump): Positive inlet pump driven by electric motor to fill oil into plant. An interlocking arrangement is provided between high liquid level switch and inlet pump to avoid excessive rise of oil level in the vacuum chambers, and flow control valve is provided to avoid damage of inlet pump by over-pressure. Meanwhile, an interlocking arrangement is provided between the inlet pump and the heater, so that heater can start only when inlet pump is ON.

(Note: If user will do oil transferring or filling without vacuum, the machine should install inlet pump)

Discharge Pump(outlet pump): Discharging oil out from the vacuum chambers held under vacuum. This is fully tested for pressure and vacuum leak rate. An interlocking arrangement between low liquid level switch and discharge pump to prevent running of discharge pump without oil, and flow control valve is provided to avoid damage of outlet pump by over-pressure.

6. Rotary Vane Vacuum Pump & Booster/Roots Vacuum pump

A rotary vane vacuum pump combining with vacuum booster(roots) pump is a sort of vacuum production equipment suitable for pumping air and make the oil purifier working under high vacuum status, this combination can improve the vacuum level more quickly.

Vacuum pump and booster/roots pump installed air cooling systems, which can ensure working of pumps safety and reduces the frequency of oil's replacement and extends the life of vacuum pump. Meanwhile, this combined vacuum pump system can be used for transformers vacuum drying.

(Note: for independent transformer vacuum drying, we suggest user to choose a digital vacuum meter(pirani gauge) or a digital vacuum transmitter)

7. Filter Elements

The filtering vessels is composed of different precision cartridge filter elements, it features unique design, large filtering area, strong particles-absorbing ability, impurities with different particulate sizes are removed step by step.

Coarse filter: The filter element is made of stainless steel mesh, which has strong capacity of retaining all particles above 100 micron. This filter element can be cleaned easily and reused.

Fine filter-1: This filter element is made of specialized glass fiber, which has large impurities holding capacity and can retaining all particles above 5 micron. This filter element can be replaced easily

Fine filter-2: This filter element allows accept a standard filter separating particles as small as 1 micron. This filter element can be replaced easily.

Pressure gauge and pressure protector is provided to ascertain condition of the filter housing and indicate replacement of filter elements to avoid the overpressure to break the filter elements.

8. Cooling Unit(Oil & Water Trap)

A cooling condenser condenses the vapors to water, where water and remained oil is collected in a condensate tank with high liquid level sensor. A condenser between vacuum pump and vacuum chamber reduces the temperature of vapor and avoids the vacuum pump damaged by high temperature of vapor and oil foam.

9. Optional: Fuller Earth Filters Column (Oil Regeneration Device)

Oil Regeneration Device adopts fuller earth filtration column for purifying and regenerating the unqualified insulating oil, it is used for removal of acids and soluble surface acting contaminants by adsorption. DR transformer oil regeneration system can increase interfacial tension of oil and reduce power factor to required levels. When water and some volatile acids are removed from oil through a prior vacuum process, adsorptive capacity of fuller earth filter for removal of remaining soluble contamination is greatly extended. The regeneration process not only corrects acidity but also

removes dirt, dust, carbon, gums, resins, abrasives and oxidation products. It provides complete and dependable protection against costly oil contamination and gives increased operating efficiency to produce better precision product

10. Pipe Work

All pipe work, the vacuum chamber and the filter housings are made from high quality carbon steel. The piping joints are flanged type with O’ring sealing.

11. Valves

Different ball valves: inlet/out valves, drain valves of all tanks, electromagnetic /solenoid valves, sample valve, air valve, by-pass valve, etc. are provided.

12. Oil Hoses

Two Nos. transparent steel spring type hoses each 10 meters long with flanged end connection on both sides are provided. Oil Hoses are capable of handling the transformer oil at 100°C (max.) and vacuum.

13. Optional Components or Brand Available

Item	Optional Brand	Optional Components
1.	Siemens or Schneider Electrical Apparatus	Online Moisture Content Monitor
2.	Siemens PLC Controller and Touch Screen	Digital Flow Meter
3.	Germany Leybold Vane Vacuum Pump	Digital Vacuum Transmitter or Vacuum Meter
4.	Germany Becker Roots Vacuum Pump	Inlet Pump
5.	Italy SEIM or STM Screw type Outlet Pump	Frequency Converter for Variable Speed Drive
6.	ABB Motor	Fuller Earth Filters(oil regeneration device)

14. Optional Equipment Available



Weather-proof



Double axles trailer



Single axle trailer